

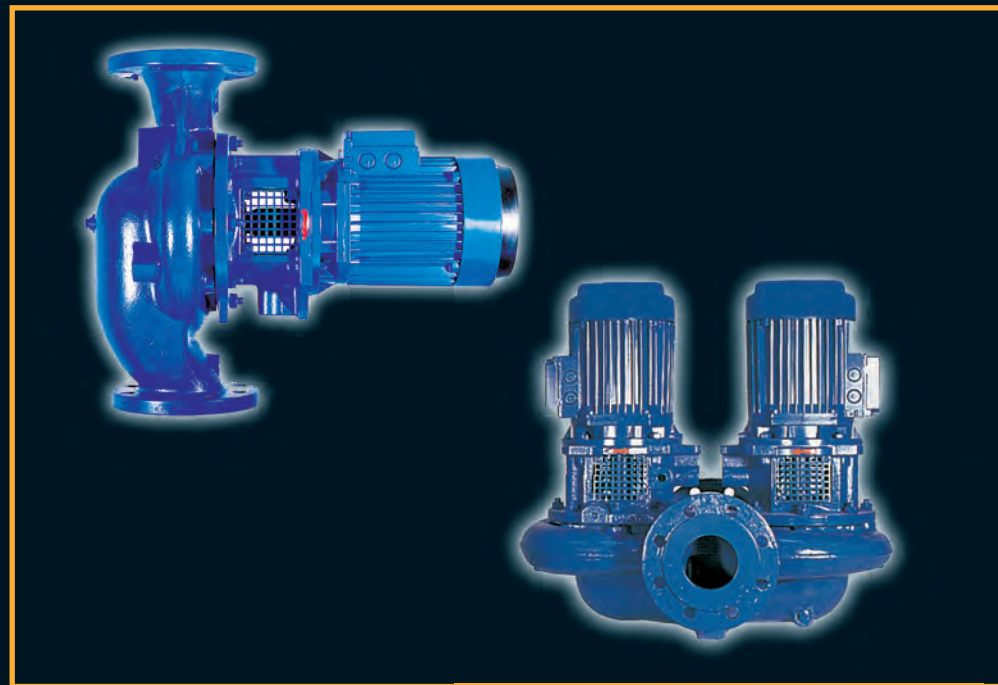

ITT

Vogel - Inline Pumps

Design LR / LMR & LRZ / LMZ, LER & LEZ



Engineered for life

VOGEL Inline Pumps, Design LR / LMR & LRZ / LMZ



Design LR, LMR



Design LMZ

Performance:

Capacity up to 350 m³/h (1540 USgpm)
 Head up to 85 m (280 feet)
 Speed up to 2950 min⁻¹ (2950 rpm)

Pump sizes:

DN 40 up to DN 150 (1 1/2" up to 6") discharge, pumps with higher capacities, sizes DN 200 up to DN 300 (8" up to 12"), refer to design LER / LEZ, page 12.

Temperature of pumped liquid:

max. 140 °C (284°F)

Casing pressure:

Design LR:
 up to 16 bar/120 °C or 13 bar/140 °C
 Design LMR/LMZ:
 up to 16 bar/120 °C or 13 bar/140 °C

Liquids:

Clean and slightly contaminated fluids (without bigger solids)
 Cold and hot water
 Condensate
 Water-Glycol mixtures, etc.

Applications:

Water supply and water treatment
 Cooling and hot water supply in industries and building services
 Filter systems, etc.

Materials:

Design	Code	Size	Impeller	Casing, Seal chamber	Wear rings	Motor adapter	Shaft
LR LRZ	VN	40-125 up to 80-160	1.4404	0.6020	1.4402	0.6020	1.4401
	NN	80-200 up to 100-250	0.6020		1)		
	SN		2.1050.01				
LMR LMZ	NN	DN 125 up to DN 150	0.6025	0.6025	1)	0.6025	1.4021
	SN		2.1050.01				

1) optional 0.6020 bzw. 0.6025



ITT

VOGEL Inline Pumps, Design LR / LMR & LRZ / LMZ

Performance 2900 r.p.m., Design LR

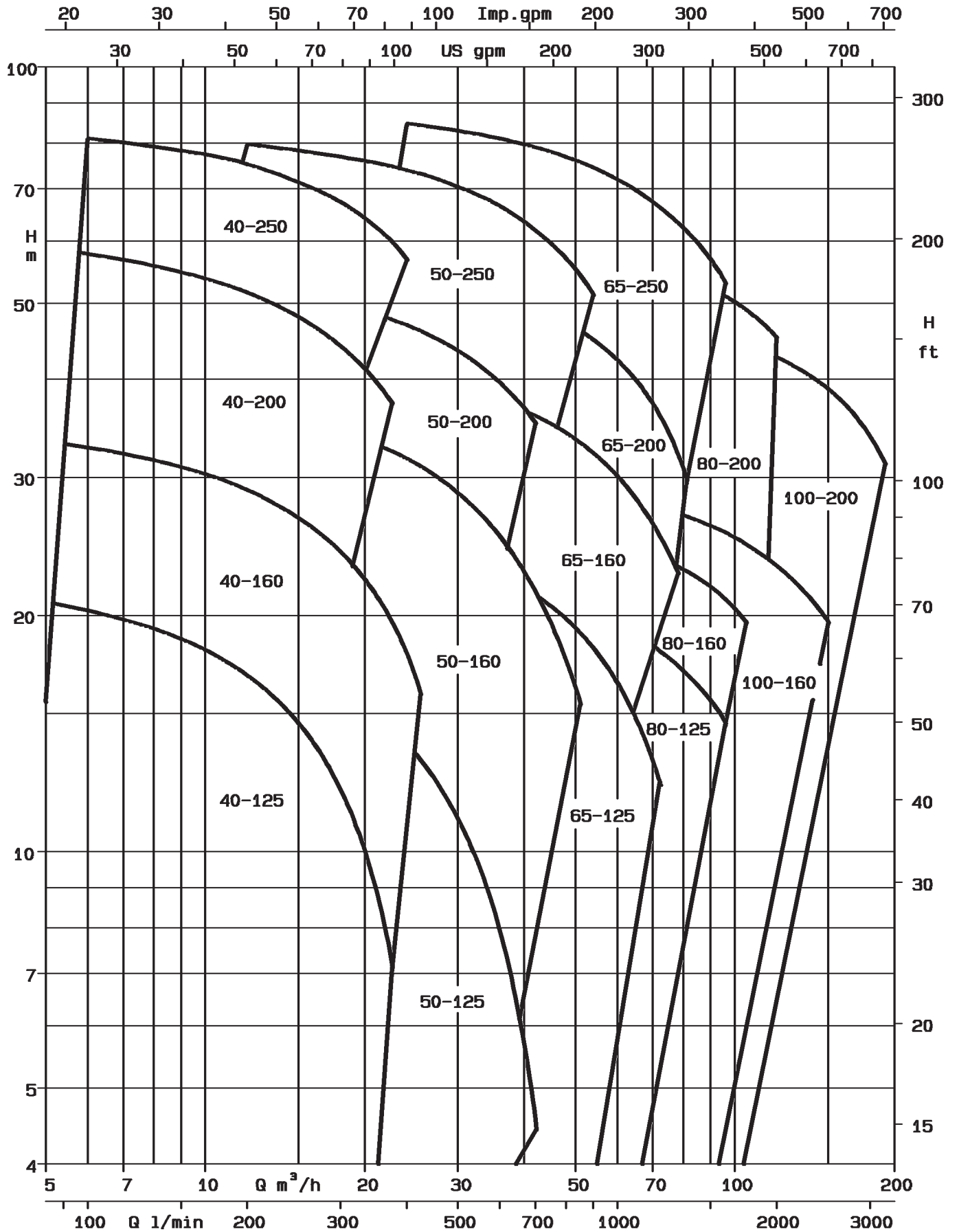

Engineered for life



ITT

VOGEL Inline Pumps, Design LR / LMR & LRZ / LMZ

Performance 1450 r.p.m., Design LR / LMR

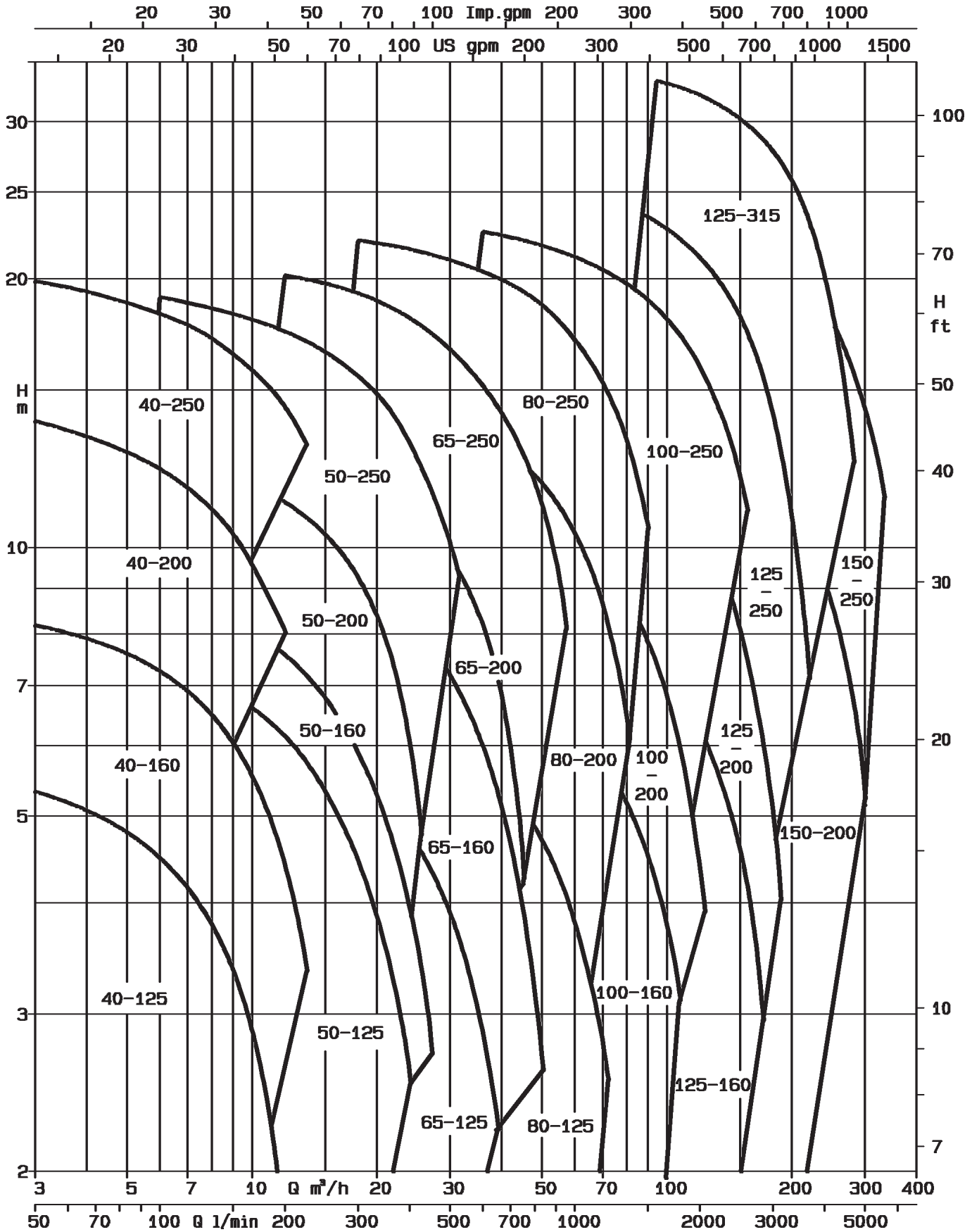

Engineered for life



ITT

VOGEL Inline Pumps, Design LR / LMR & LRZ / LMZ

Performance 2900 r.p.m., Design LRZ - Single operation

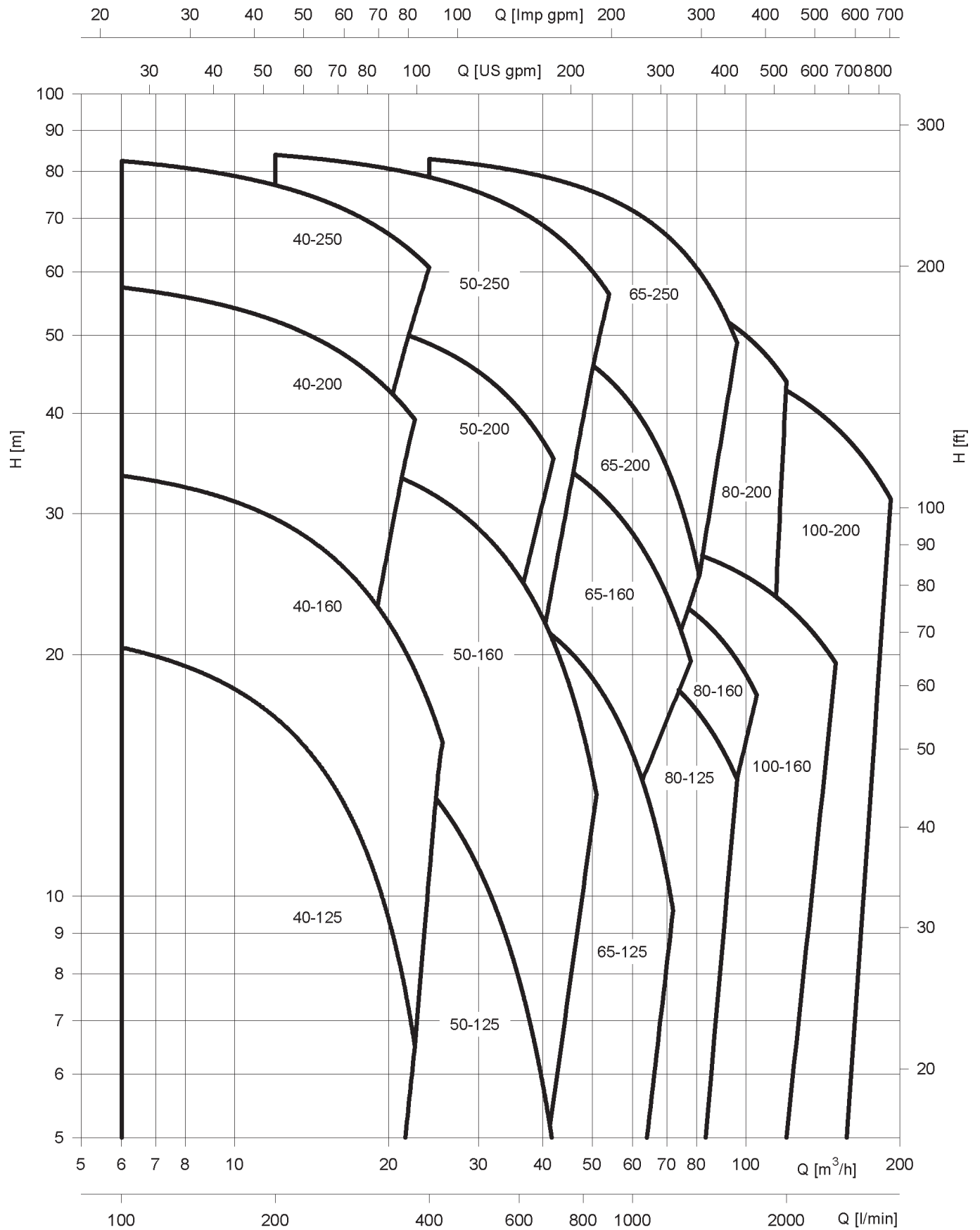

Engineered for life



VOGEL Inline Pumps, Design LR / LMR & LRZ / LMZ
Performance 2900 r.p.m., Design LRZ - Parallel operation

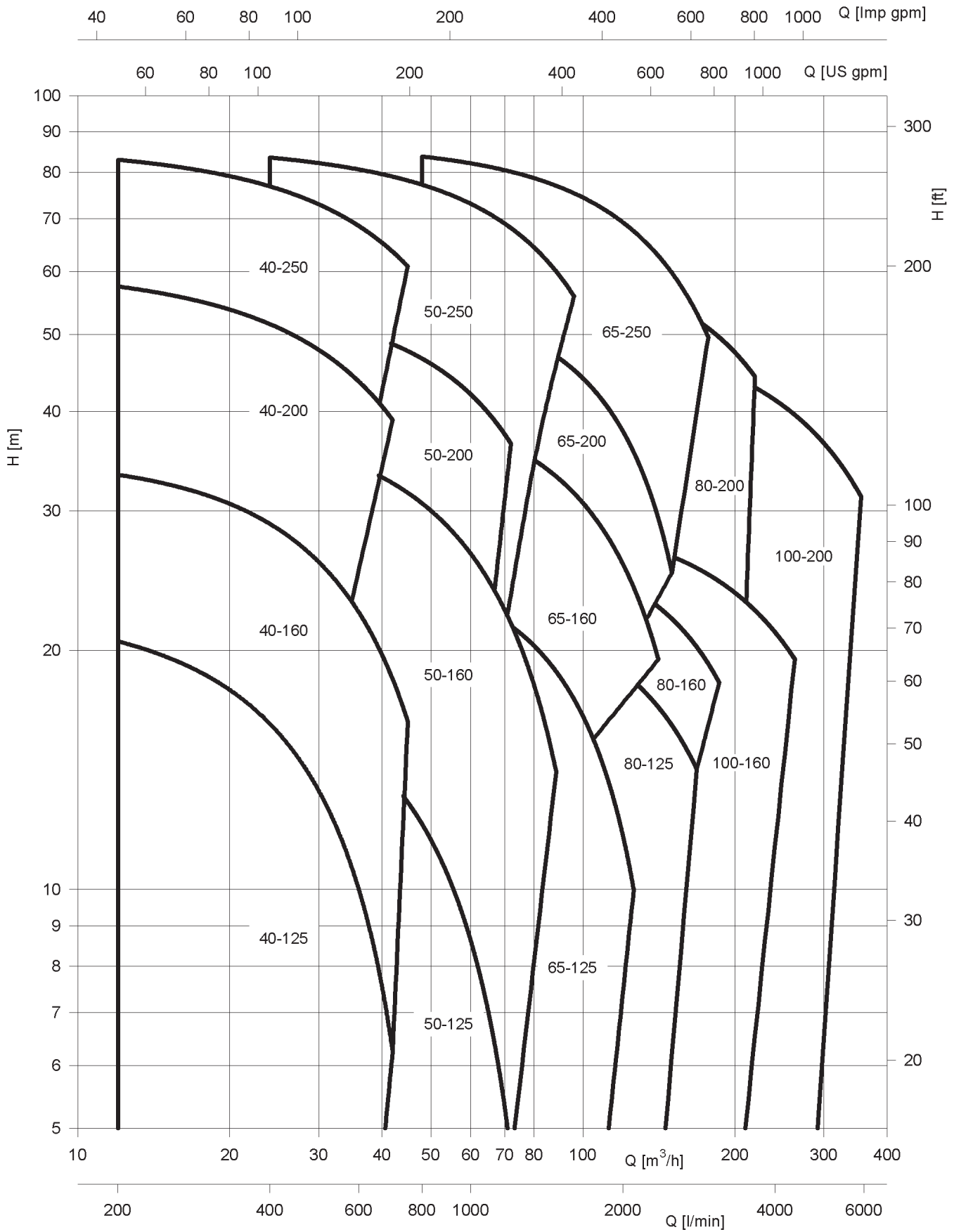



VOGEL Inline Pumps, Design LR / LMR & LRZ / LMZ

Performance 1450 r.p.m., Design LRZ - Single operation

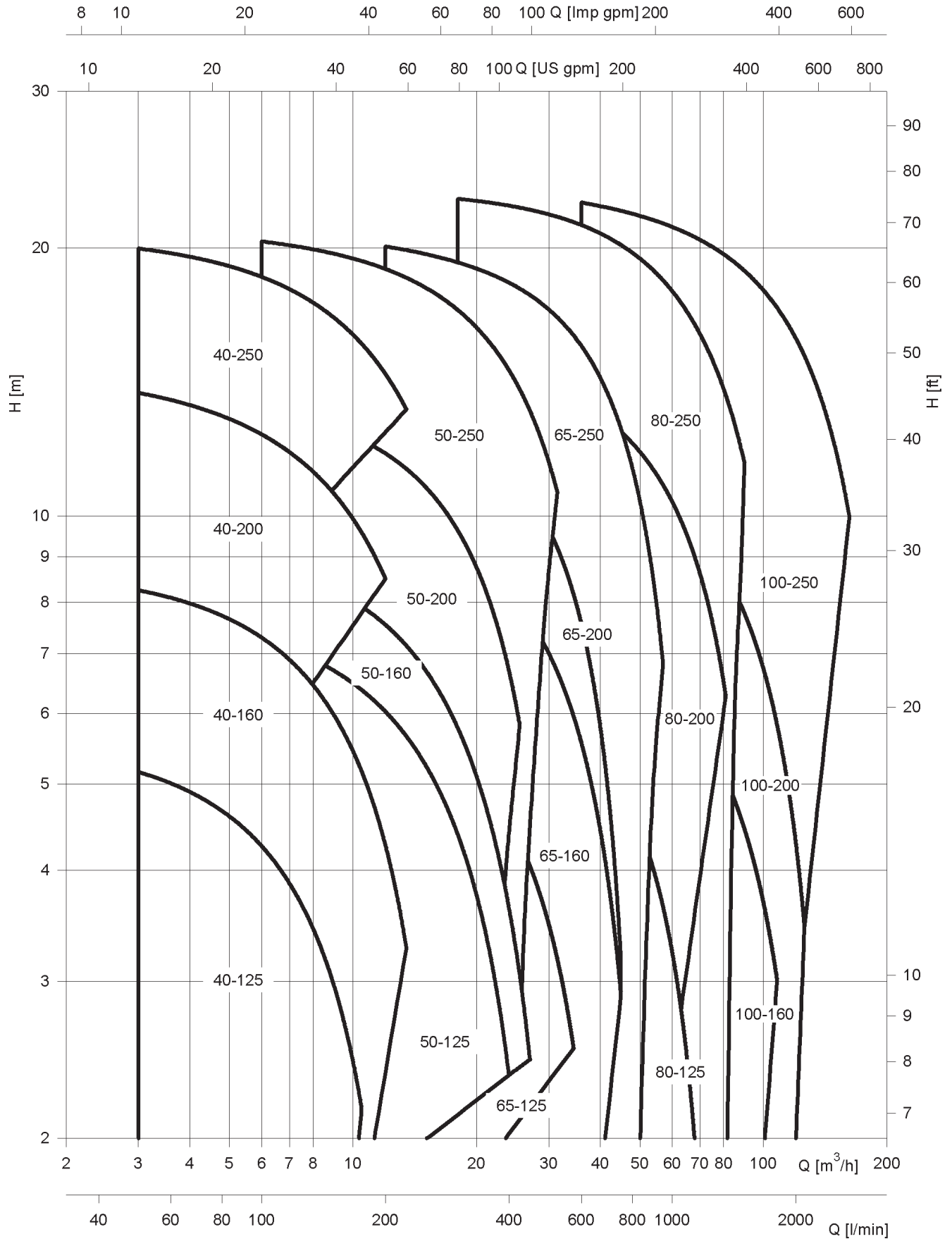



ITT

VOGEL Inline Pumps, Design LR / LMR & LRZ / LMZ

Performance 1450 r.p.m., Design LRZ - Parallel operation

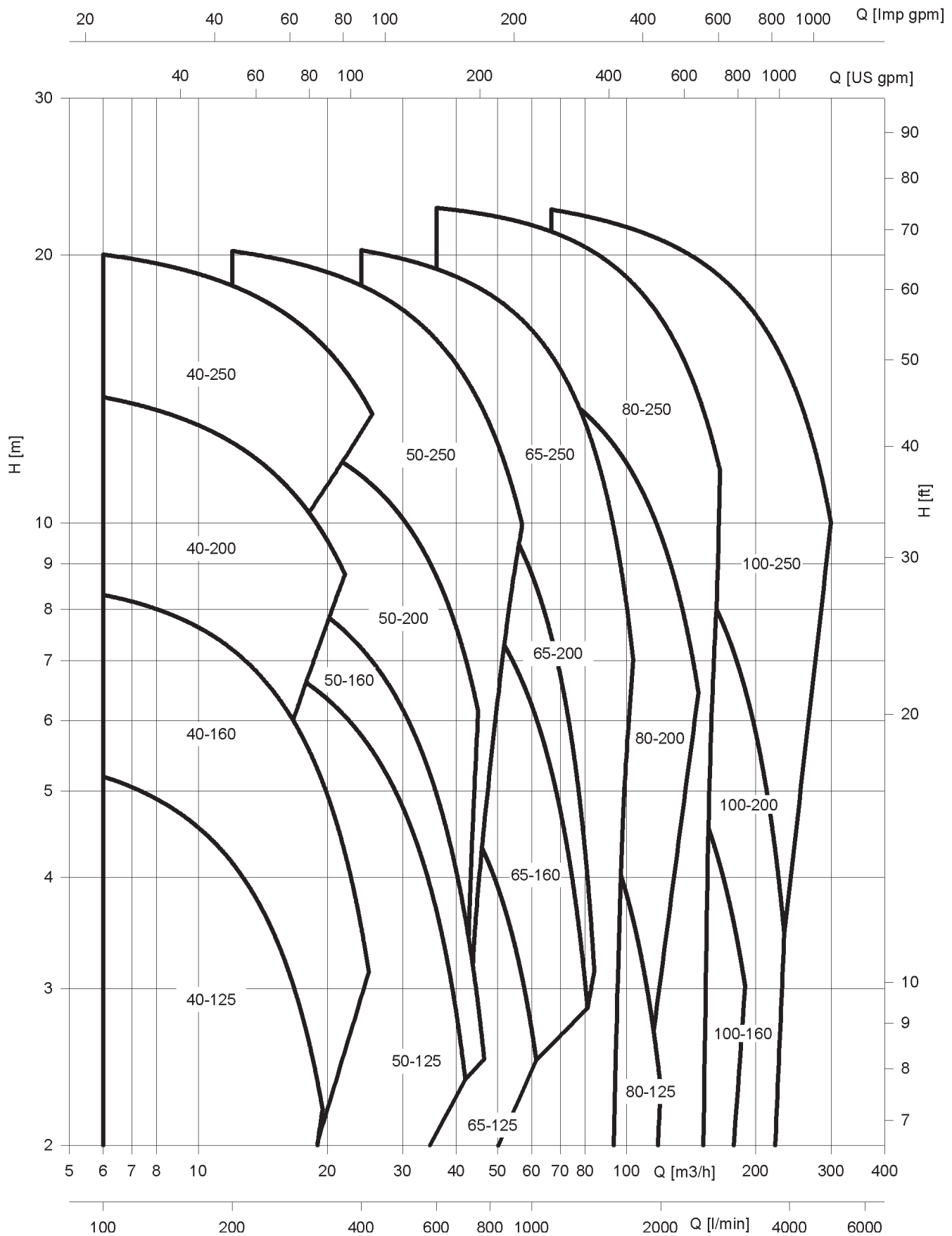

Engineered for life



ITT

VOGEL Inline Pumps, Design LR / LMR & LRZ / LMZ

Performance 1450 r.p.m., Design LMZ

Single operation

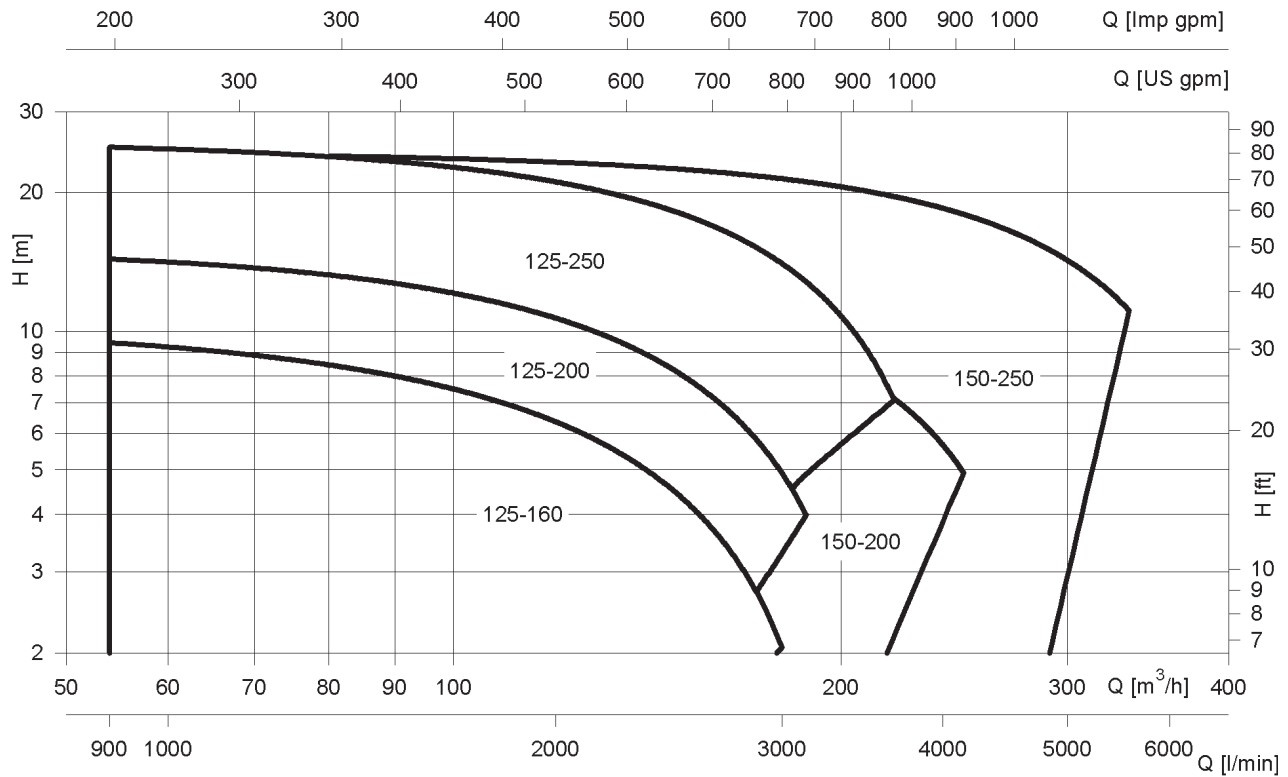

Parallel operation

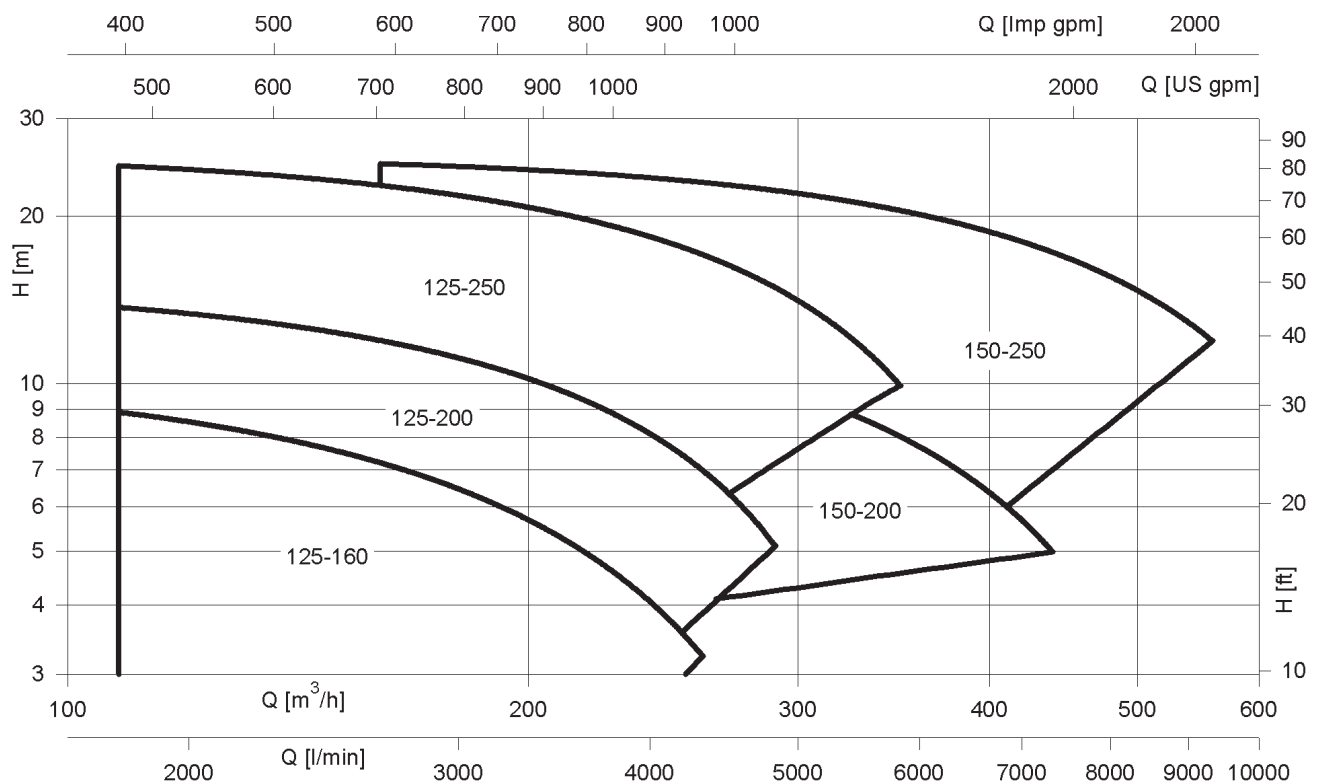

Engineered for life

VOGEL Inline Pumps, Design LR / LMR & LRZ / LMZ

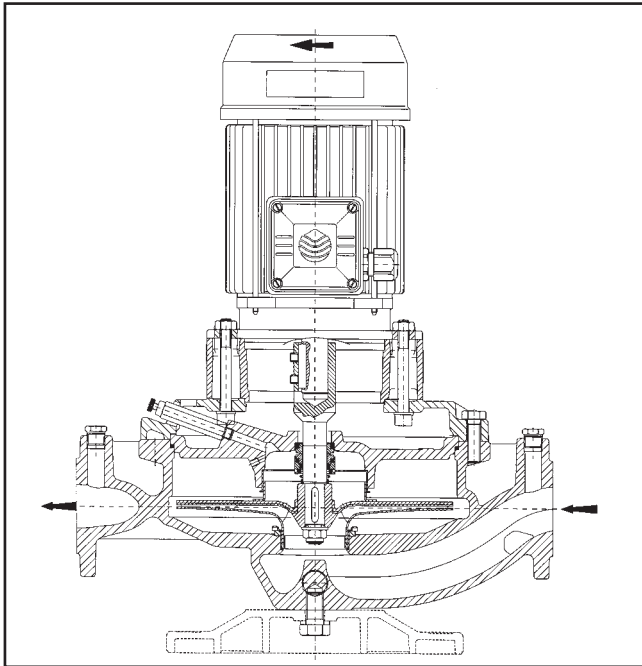

Design LR

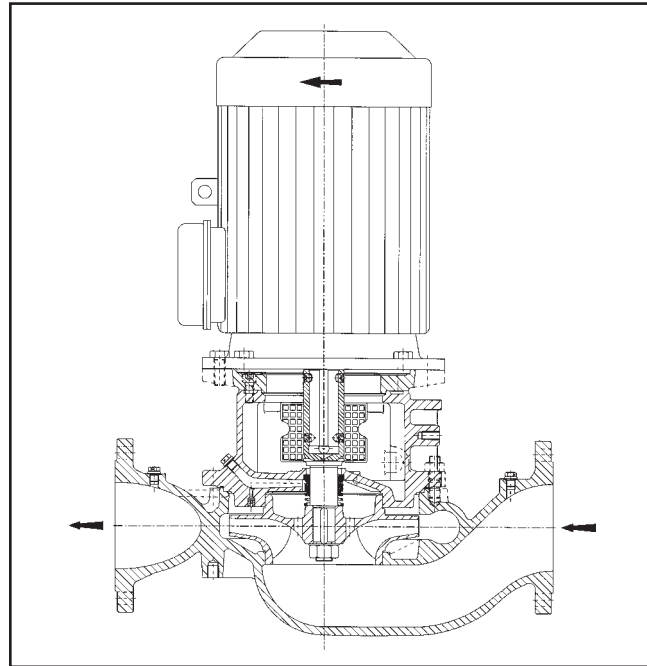

Design LMR

Design features LR, LMR:

- Single stage volute casing pump in Inline design with direct mounted standard IEC Norm Motor.
- Meet the requirements according to ISO 9908
- High efficiency enclosed impeller. Sizes 40-125 up to 80-160 standard made of stainless steel 1.4404, stamped and laser welded. Sizes 80-200 up to 150-250 standard cast iron, optional bronze.
- Casing in solid design. Suction and discharge Inline. Flanges DN 40 up to DN 150 standard PN 16.
- Seal chamber dimensioned according to EN 3096
- Large open conical seal chamber, selfventing with internal circulation for proper lubrication and cooling of the seal. Ribs in the seal chamber prevent the accumulation of air or gas in the area of the seal faces and reduce wear caused by solids in the fluid.
- Shaft sealing by means of single, unbalanced mechanical seal according to EN 12756, design U, version k (former DIN 24 960, I1k).
- Standard mechanical seal materials: Carbon – Silicon Carbide (SiC) – EPDM (BQ1EGG), optional elastomers in FPM (Viton®) (BQ1VGG).
As option also available in SiC – SiC – FPM (Viton®) (Q1Q1VGG).
- Solid motor adapter made of cast iron to connect directly standard IEC Norm Motors, design B5/V1.
- Pump shaft designed as stub shaft and completely made of stainless steel for a long lifetime, directly connected to the motor shaft.



ITT

VOGEL Inline Pumps, Design LR / LMR & LRZ / LMZ

With stub shaft and standardized motor

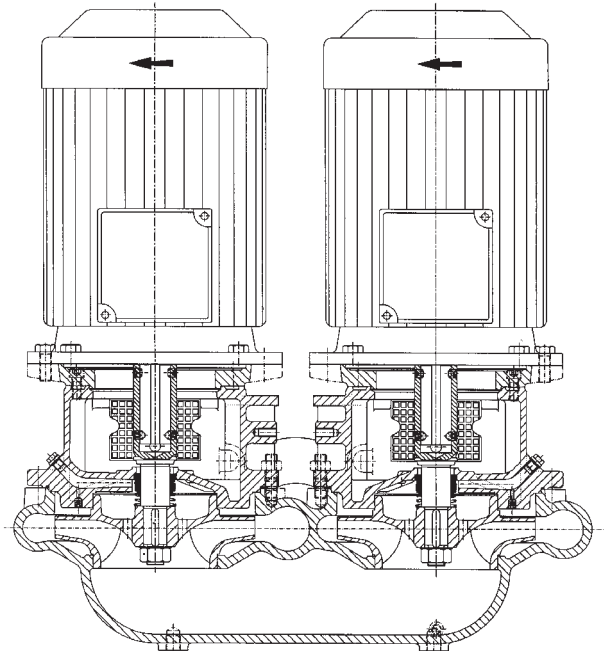
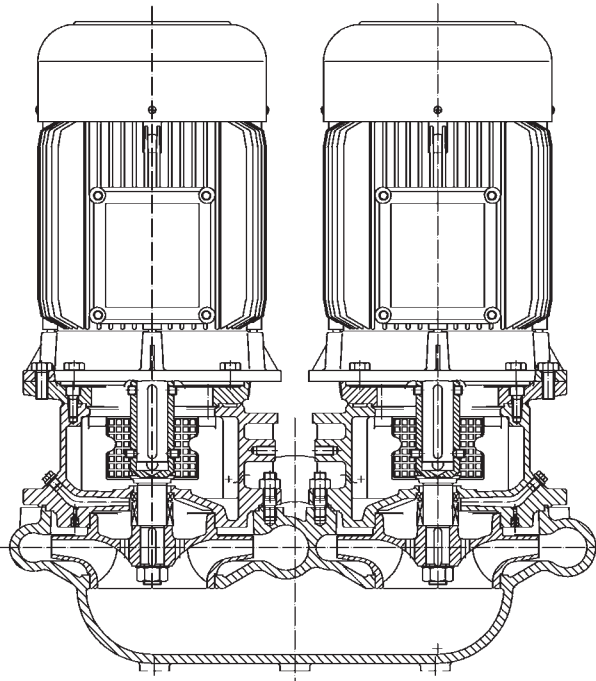

Close-coupled with special motor shaft extension

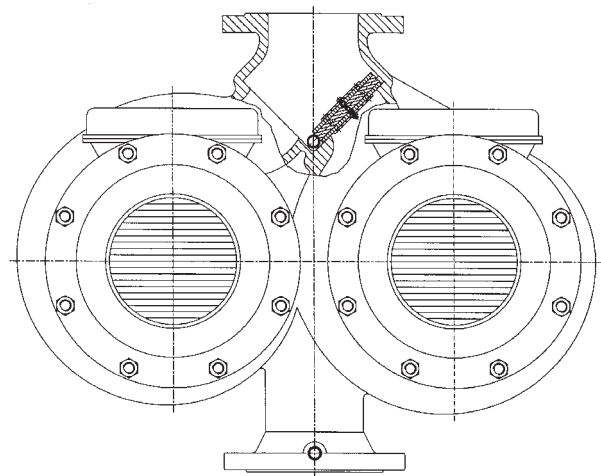
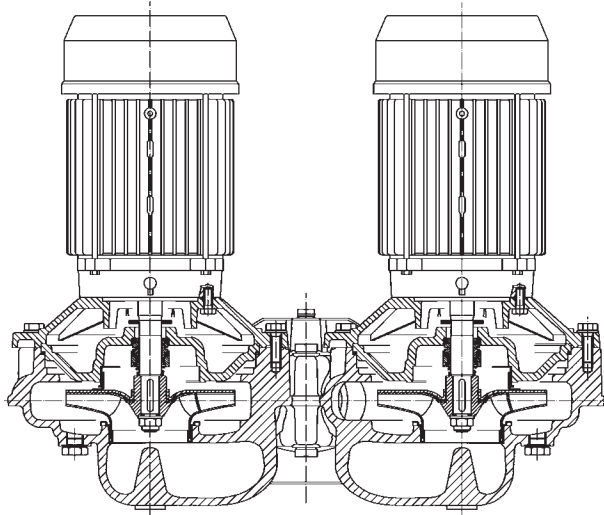

Design LRZ

Design LMZ

Design features LRZ / LMZ:

- Single stage volute casing pump in Inline design with direct mounted standard IEC Motor.
- Operation and stand-by pump in a common casing with integrated automatic reversing flap.
- Drive unit (Impeller and motor) are identical and also identical with the single Inline pump LMR.
- Other features identical with Series LMR.

VOGEL Inline Pumps, Design LER / LEZ - Extension Program



Design LER



Design LEZ

Performance:

Capacity up to 1000 m³/h (4400 USgpm)
 Head up to 80 m (262 feet)
 Speed up to 2950 min⁻¹ (2950 rpm)

Pump Sizes:

DN 100 up to DN 300 (4" up to 12") discharge

Temperature of pumped liquid:

Max. 150 °C (302 °F)

Casing pressure:

Design LER/LEZ: 10 bar/120 °C
 Design LERS: 16 bar/150 °C

Liquids:

Clean and slightly contaminated fluids
 (without bigger solids)
 Cold and hot water
 Condensate
 Water-Glycol mixtures, etc.

Applications:

Water supply and water treatment
 Cooling and hot water supply in industries and
 building services engineering
 Filter systems, etc.

Materials:

Design	Size	Code	Impeller	Casing, Seal chamber	Wear rings	Motor adapter	Shaft
LER LERS	DN 100 up to DN 250	NN	0.6020	0.6020	without	0.6020	1.4460
		NL	0.6020	0.7040			
	DN 300	LN	0.7040	0.6020			
		LL		0.7040			
LEZ	DN 125 up to DN 250	NN	0.6020	0.6020			
		NL		0.7040			

VOGEL Inline Pumps, Design LER / LEZ - Extension Program

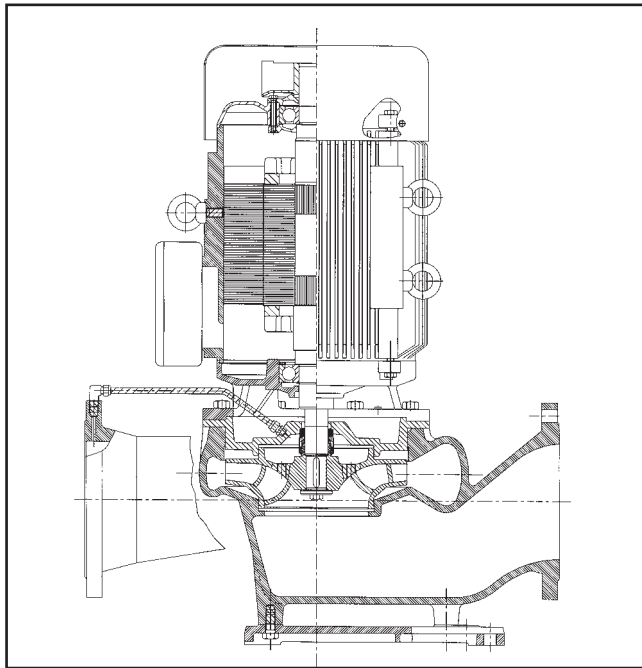

Design LER

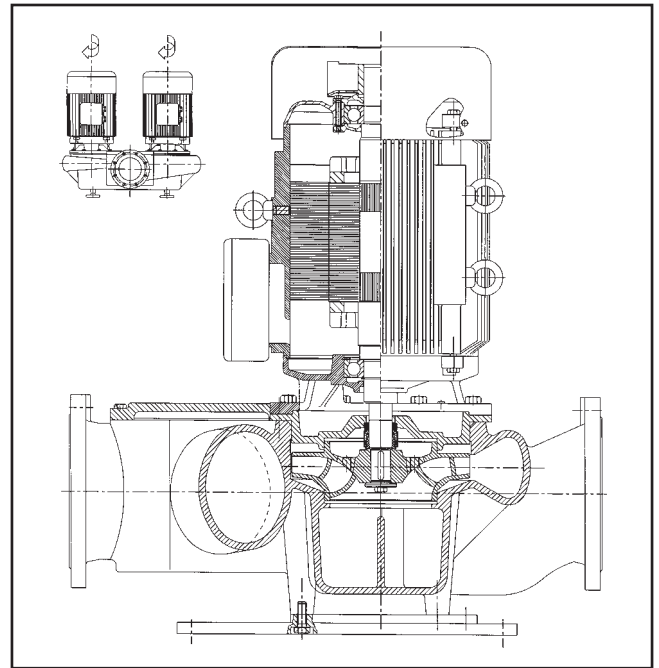

Design LEZ

Design Features LER / LEZ:

- Single stage volute casing pump in Inline design with direct mounted Motor with one motor and pump shaft.
- Design LER Single Inline Pump
- Design LEZ Twin-Inline Pump. Operation and stand-by pump in one common casing with integrated automatic reversing flap.
- Meet the requirements according to ISO 9908
- High efficiency enclosed impeller. Standard made of cast iron, optional bronze.
- Casing in solid design. Suction and discharge Inline. Flanges PN 10, optional for Design LERS, PN 16.



VOGEL Inline Pumps - HYDROVAR®

Sensorless HYDROVAR® - Application examples



The sensorless control system is a new way to control the pump speed!

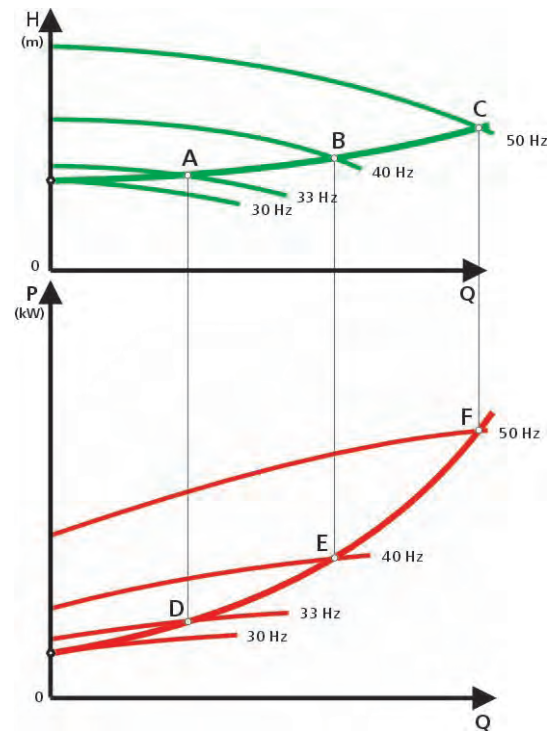

The HYDROVAR-Sensorless System works without any external Sensors (pressure capacity)!
The controller works based on the measured power consumption curve over the capacity.
Power 1.1. up to 11 kW.



ITT

VOGEL Inline Pumps, Design LR / LMR & LRZ / LMZ, LER & LEZ

Program Extension

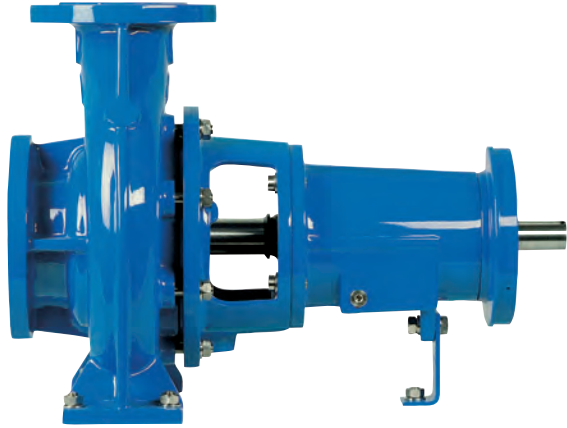

Design L

Volute Casing Pumps LN / L:

- Single Stage Volute Casing pump according to EN 733 / ISO 9908
- Sizes from DN 32 up to DN 150 (1 1/4" up to 6")
- Capacities up to 600 m³/h (2640 USgpm)
- Heads up to 100 m (328 feet)



Design LM

Blockpumps LMN / LM:

- Horizontal single stage block pump with direct mounted IEC-Norm Motor
- Sizes from DN 32 up to DN 150 (1 1/4" up to 6")
- Capacities up to 500 m³/h (660 USgpm)
- Heads up to 95 m (312 feet)
- Motor Sizes up to 55 kW (75 hp)

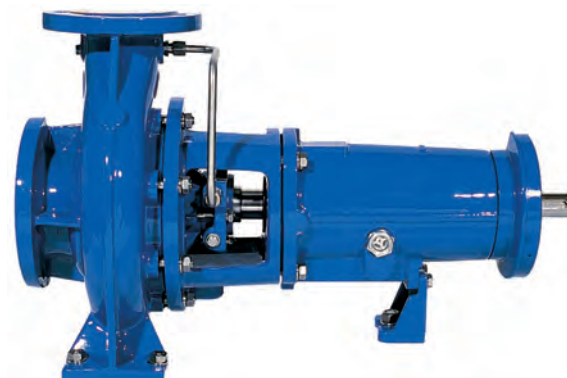

Design LS

Volute Casing Pumps LS:

- Extension of the performance range of model LN/L
- Horizontal Design according to ISO 5199
- Sizes from DN 125 up to DN 600 (5" up to 24")
- Capacities up to 4600 m³/h (20250 USgpm)
- Heads up to 100 m (328 feet)



ITT

ITT Austria GmbH

A-2000 Stockerau

Ernst Vogel-Straße 2

Telefon: ..43-2266-604

Telefax: ..43-2266-65311

E-Mail: info.ittaustria@itt.com

www.ittaustria.com

„Hinweis gemäß Produkthaftungsgesetz:

Die angeführten Einsatzmöglichkeiten sind nur als eine Produktübersicht aufzufassen. Die genauen Einsatzgrenzen sind dem Angebot, der Auftragsbestätigung und der Betriebsanleitung zu entnehmen.“

Liste 1160.1.B
10/2005-e



Engineered for life